

Thanks for shopping with Jeco®

Resin Wicker 5pc Sofa Set w/ Cushions

SKU # W00503

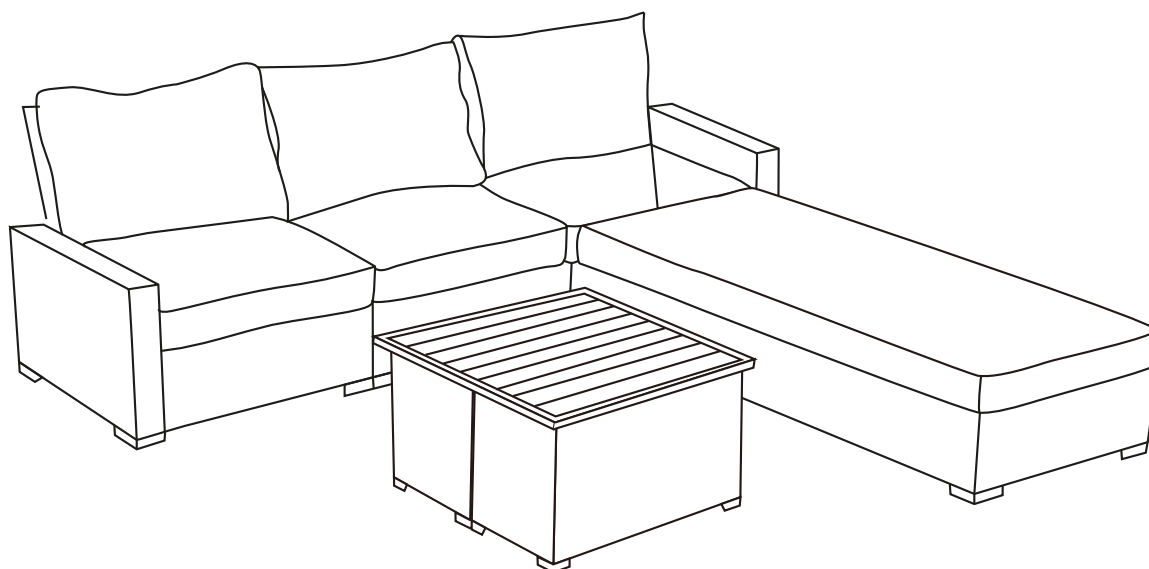

IMPORTANT:

Please read all the instructions and warnings before assembling. In order to make the whole product adjust to the best, please install all the screws on the product before full tightening!

WARNING:

- _ Keep all children and pets away from assembly area. Children and pets should be supervised when they are in the area of the product construction.
- _ Keep assembly area at least 6 feet from any obstruction such as a fence, garage, house, overhanging branches, laundry line or electrical wires.
- _ Some parts may contain sharp edges. When assembling and using this product, basic safety precautions should always be followed to reduce the risk of personal injury and damage to the product. Please read all instructions before assembly and use.
- _ Check all bolts for tightness before use. **IMPORTANT** - check and tighten bolts often to keep them secure!
- _ The chairs are not to be used for standing purposes and will not function as a stool or step-ladder. Use on even surfaces only.





JECO

1-800-893-3006
Ontario, CA 91761



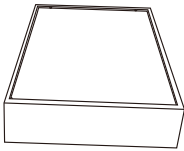
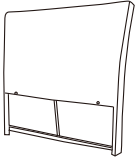
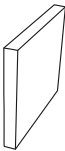
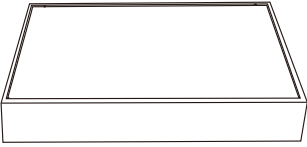
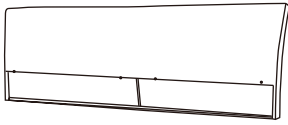

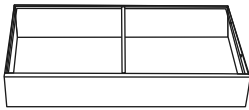
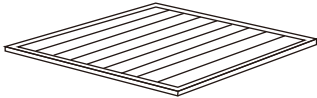
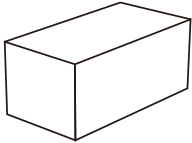
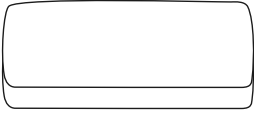
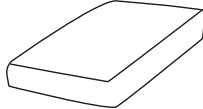
Made in China

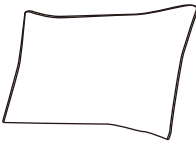
If you have questions regarding this product, call
1-800-893-3006 Mon.-Fri. 9:00-5:00 PST
(California) and ask for our product specialists, or
e-mail: cs@jeco-inc.com
See many more products on the Internet!
www.jeco-inc.com

Parts List:

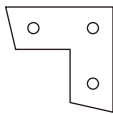
<p>A. Short Seat Panel Qty: 1</p> 	<p>B. Short Chair Back Qty: 1</p> 	<p>C. Right Arm Qty: 1</p> 
<p>D. Long Seat Panel Qty: 1</p> 	<p>E. Long Chair Back Qty: 1</p> 	<p>F. Left Arm Qty: 1</p> 
<p>G. Chaise Qty: 1</p> 	<p>H. Table Top Qty: 1</p> 	<p>I. Ottoman Qty: 2</p> 
<p>J. Chaise Cushion Qty: 1</p> 	<p>K. Ottoman Cushion Qty: 2</p> 	<p>L. Seat Cushion Qty: 3</p> 
<p>M. Back Cushion Qty: 3</p> 		

Hardware List:

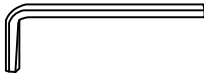
<p>N. "7" Shape Feet Qty: 20</p> 	<p>O. Feet Screws (3*50) Qty: 60</p> 	<p>P. Screw (6*35) Qty: 15</p> 
<p>Q. Flat Washer Qty: 15</p> 	<p>R. Allen Wrench Qty: 1</p> 	

To Assemble:

Step 1

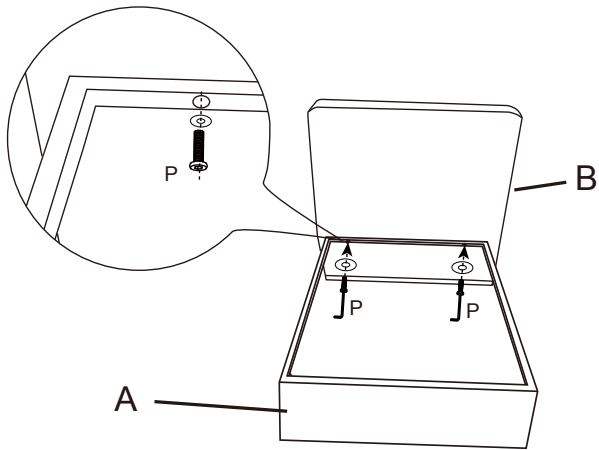

Step 2

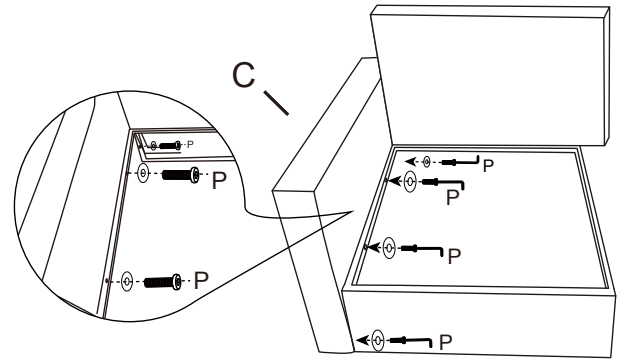

Step 3

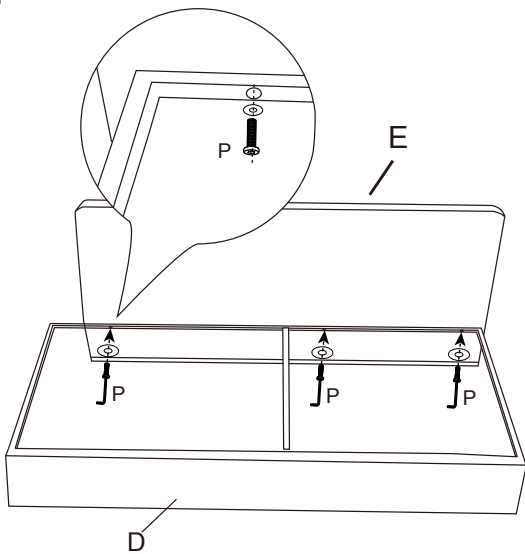

Step 4

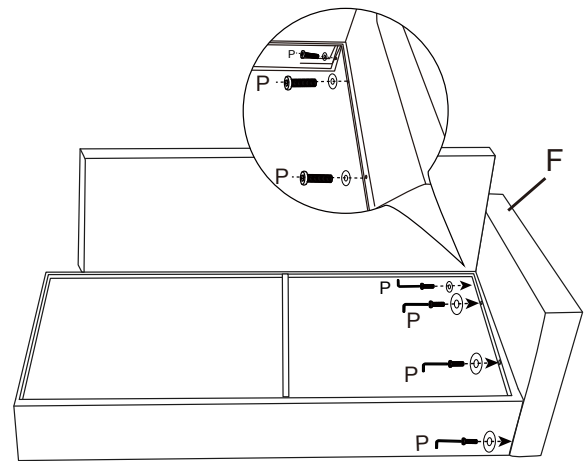

Step 5

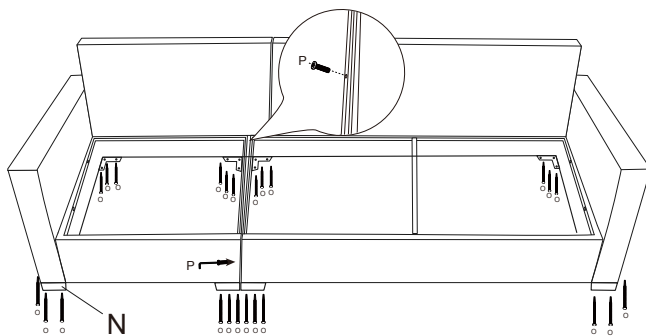

Step 6

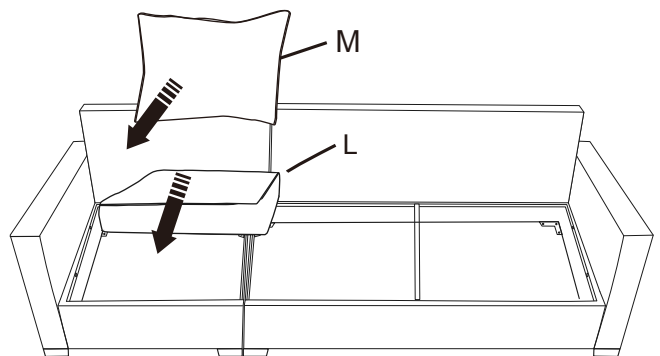

Step 7

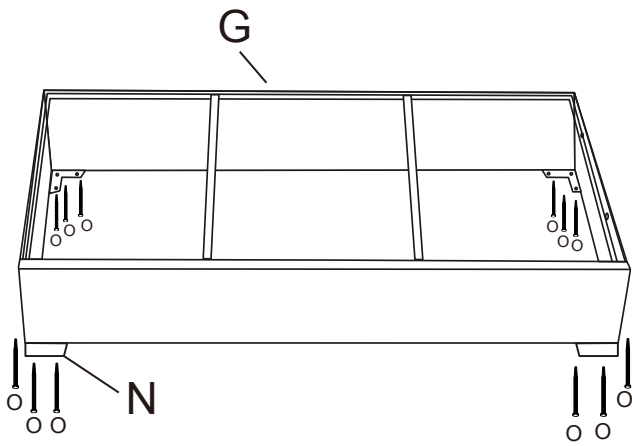

Step 8

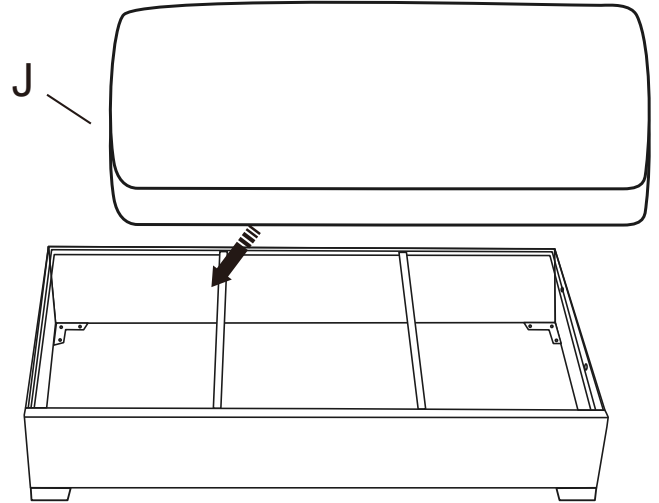

Step 9

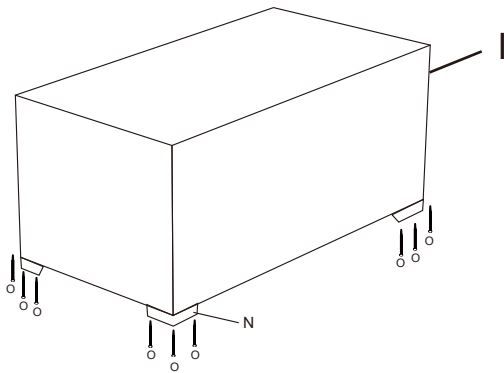

Step 10

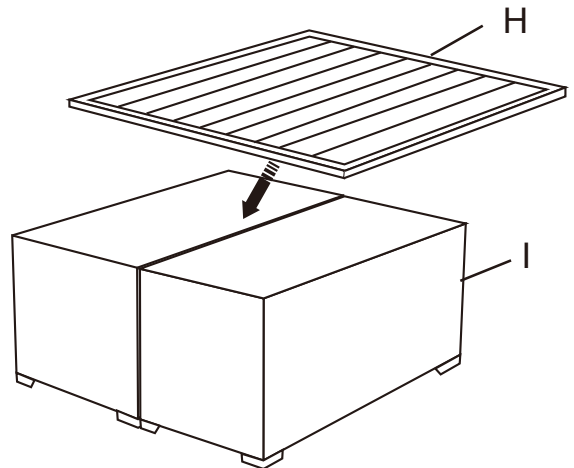

Step 11

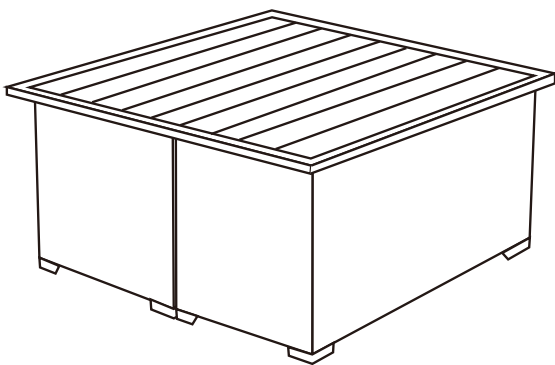

Step 12

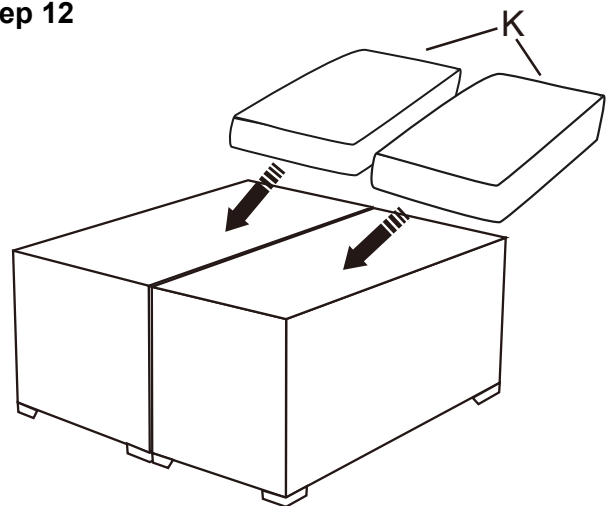

Care & Maintenance:

SPILLS:

Immediately wipe up the spill using a white damp cloth. Repeat process if necessary until stain is gone. Allow cushion to air dry.

FABRIC CARE:

Hand wash cold, non-chlorine bleach when needed, lay flat to dry. Or remove cushion cover, wash with hands, non-chlorine bleach. Air dry. Cool iron if necessary. Do not dry clean.

RESIN WICKER PRODUCT CARE:

Before using, clean the product completely with a soft dry towel. When not in use, wipe free of any dirt or loose objects, wash with a mild solution of soap and water; rinse thoroughly and dry completely. Do not use strong detergent or abrasive cleaners. Over time nuts and bolts can loosen. Occasionally, check nuts and bolts on all chairs and table, re-tighten if necessary.