

Assembly Instructions

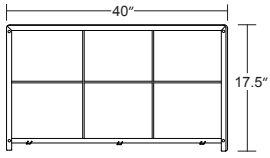

(A) Body - Long Side Qty: 2

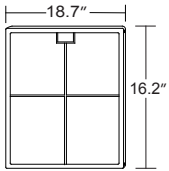

(B) Body - Short Side Qty: 2

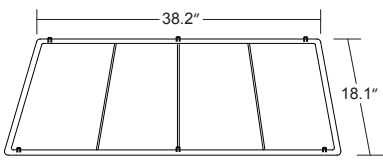

(C) Bottom Panel Qty: 1

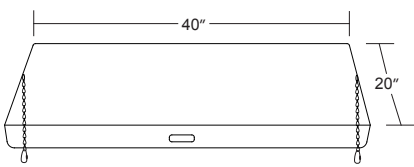

(D) Lid Qty 1

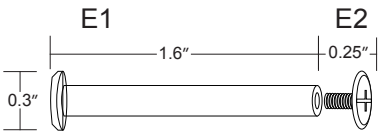

(E) Bolt Qty: 2

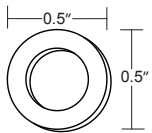

(F) Washer Qty: 8

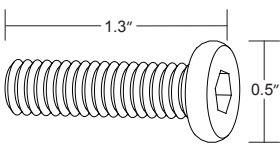

(G) Screw Qty: 8

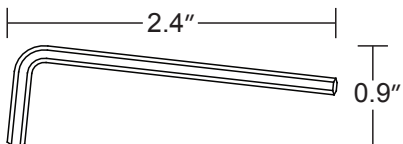

(H) Allen Wrench Qty: 1

STEP 1:

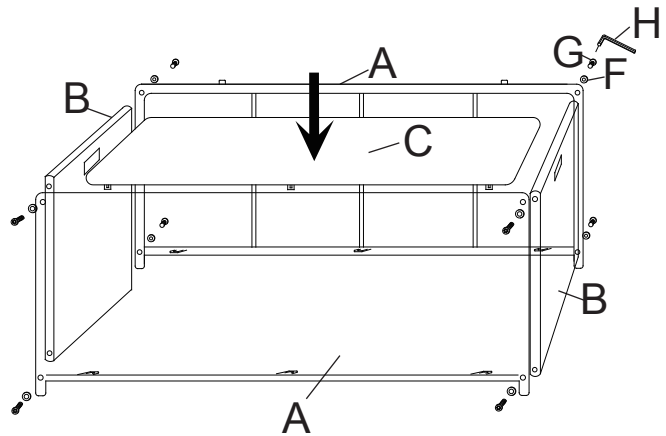

STEP 2:

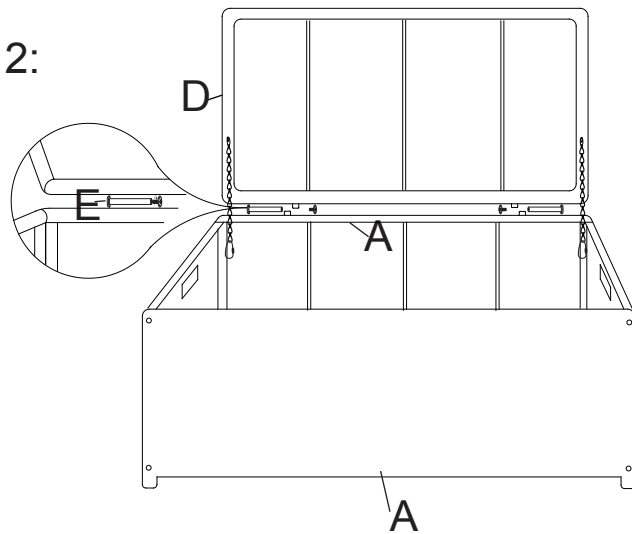

STEP 3:

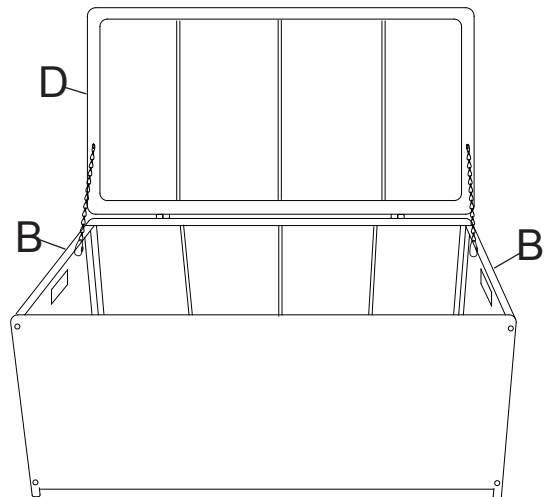

COMPLETE

